

Information provided on this form must be accurate or equipment will not perform properly.

After completing this form please return to ATEK. Questions contact ATEK CCT 800-523-6996.

Email: cct@tankscan.com, Fax: 800-589-3705 ATTN: TankScan CCT

Customer Information

Company Name: _____

Site Name: _____

Gateway Information¹

Gateway #1, MAC ID² | 00409D _____

Gateway #2, MAC ID² | 00409D _____

Gateway #3, MAC ID² | 00409D _____

1. For TSM8000 Monitors only. TSU Monitors do not use Gateways.

2. Gateway MAC ID's begin with "00409D", installer must fill in remainder.

Installer Information

Installer Company: _____

Installer Name: _____

Install Date: _____

Signing below signifies that both the customer and installer are satisfied with the work completed and the TankScan system is functioning to the customer's satisfaction.

Authorized Customer Signature or Printed Name: _____

Date: _____

Authorized Installer Signature or Printed Name: _____

Date: _____

Notes: _____

Vertical Cylindrical Tanks With or Without a Crown



The power of data. **Optimized.**

All Dimensions Must be in Inches.

TANK NAME	MONITOR S/N	MEASURE OUTSIDE OF TANK		MEASURE AFTER CUTTING TO LENGTH	INTERNAL TANK MEASUREMENTS		MEASURE OUTSIDE OR TAKE FROM STRAPPING TABLE
		RISER HEIGHT	SIDEWALL HEIGHT	PROBE LENGTH ¹	FLUID HEIGHT	TOTAL HEIGHT	TANK DIAMETER

1. TSM8000 Monitors Only

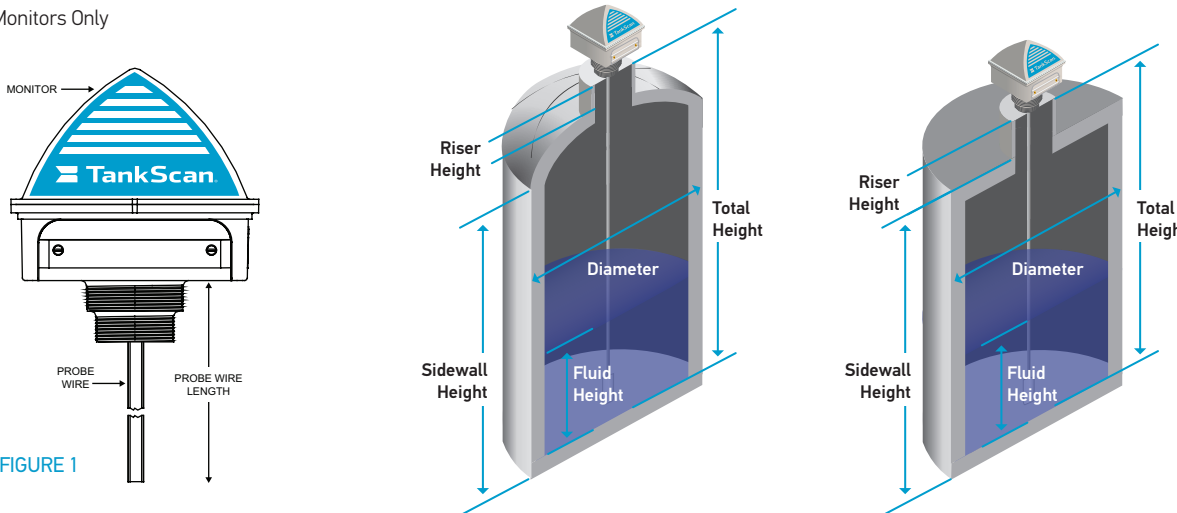

FIGURE 1

TSU Monitor Serial Number



TSM8000 Monitor Serial Number



Horizontal Cylindrical Tanks With or Without End Caps



The power of data. Optimized.

All Dimensions Must be in Inches.

TANK NAME	MONITOR S/N	MEASURE OUTSIDE OF TANK		MEASURE AFTER CUTTING TO LENGTH	INTERNAL TANK MEASUREMENTS		MEASURE OUTSIDE OR TAKE FROM STRAPPING TABLE		
		RISER HEIGHT	DIAMETER	PROBE LENGTH ¹	FLUID HEIGHT	TOTAL HEIGHT	C1-IF TANK HAS END CAPS	C2-IF TANK HAS END CAPS	LENGTH

1. TSM8000 Monitors Only

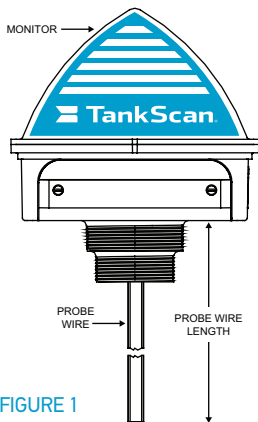
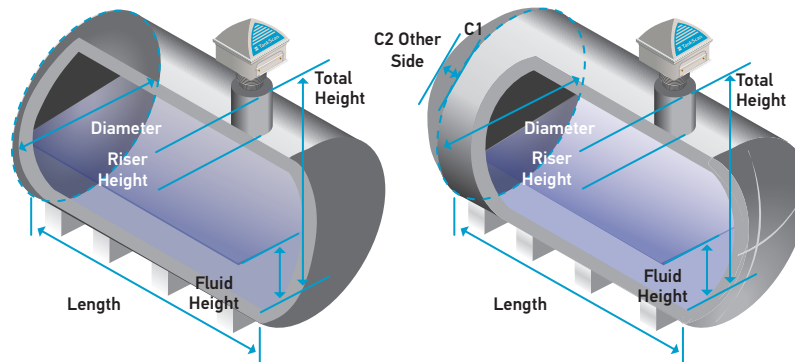

FIGURE 1



TSU Monitor Serial Number



TSM8000 Monitor Serial Number



All Dimensions Must be in Inches.

TANK NAME	MONITOR S/N	MEASURE OUTSIDE OF TANK		MEASURE AFTER CUTTING TO LENGTH	INTERNAL TANK MEASUREMENTS		MEASURE OUTSIDE OR TAKE FROM STRAPPING TABLE	
		RISER HEIGHT	SIDEWALL HEIGHT	PROBE LENGTH ¹	FLUID HEIGHT	TOTAL HEIGHT	LENGTH	WIDTH

1. TSM8000 Monitors Only

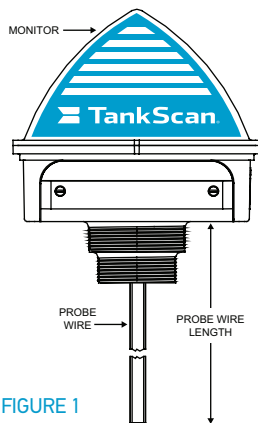
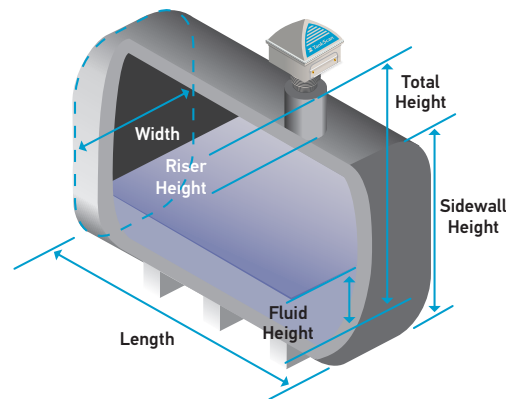

FIGURE 1



TSU Monitor Serial Number



TSM8000 Monitor Serial Number



Rectangular Tanks



The power of data. **Optimized.**

All Dimensions Must be in Inches.

TANK NAME	MONITOR S/N	MEASURE OUTSIDE OF TANK		MEASURE AFTER CUTTING TO LENGTH	INTERNAL TANK MEASUREMENTS		MEASURE OUTSIDE OR TAKE FROM STRAPPING TABLE	
		RISER HEIGHT	SIDEWALL HEIGHT	PROBE LENGTH ¹	FLUID HEIGHT	TOTAL HEIGHT	LENGTH	WIDTH

1. TSM8000 Monitors Only

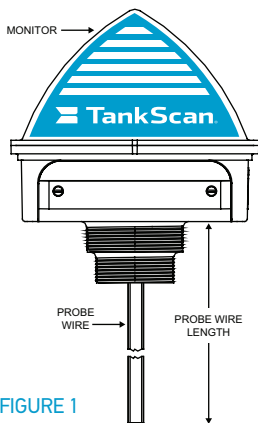
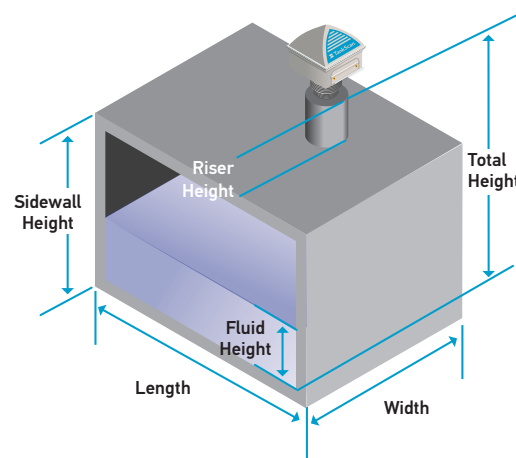

FIGURE 1



TSU Monitor Serial Number



TSM8000 Monitor Serial Number



ATEK Access Technologies
10025 Valley View Road, Ste. 190
Eden Prairie, MN 55344 U.S.A.

PH: 1.800.523.6996
FAX: 1.800.589.3705
+1.218.829.9797

www.atekaccess.com



Access the power of technology.